

Test **CSA A440-00 Windows**
Method:

Manufacturer/Client: Oasis Windows Ltd.	Manufacturer/Client Address: 109-12889 84 th Street Surrey, British Columbia Canada
Job Number: W410-5	
Sample Number: 300 Series Horizontal Sliding Window	Description: Width: 1600mm, Height: 1000mm See report for details.
Date Received: June 2006	
Test Technician(s): Adam Perczyk	Testing Performed at: Quality Auditing Institute Ltd 2825 Murray Street Port Moody, BC Canada, V3H 1X3
	Date(s) of Testing: July 26, 2006 – August 1, 2006

REPORT NUMBER W410-5

Edition 1: August 28, 2006
Contents: Pages 1-16, A1-A10

Table of Contents

Sampling Plan/Procedures:.....	3
Test Equipment:	3
Test Conditions:	4
Summary of Results:.....	5
Window Components:.....	6
Test Specifications:	7
AIR TIGHTNESS TEST: CSA A440-00, CLAUSE 10.2, TEST METHOD: ASTM E283.....	7
WATER TIGHTNESS TEST: CSA A440-00, CLAUSE 10.3, TEST METHOD: ASTM E547	8
WIND LOAD RESISTANCE TEST: CSA A440-00, CLAUSE 10.4, TEST METHOD: ASTM E330	9
SAFETY DROP – VERTICAL SLIDING WINDOWS: CSA A440-00, CLAUSE 10.5:.....	12
BLOCKED OPERATION TEST: CSA A440-00, CLAUSE 10.6:.....	12
SASH STRENGTH AND STIFFNESS: CSA A440-00, CLAUSE 10.7:.....	12
SASH STRENGTH AND STIFFNESS: CSA A440-00, CLAUSE 10.8:.....	12
EASE OF OPERATION TEST: CSA A440-00, CLAUSE 10.9:	12
INSECT SCREEN STRENGTH CSA A440-00, CLAUSE 10.10:.....	13
SASH PULL-OFF CSA A440-00, CLAUSE 10.11:.....	13
CONDENSATION RESISTANCE: CSA A440-00, CLAUSE 10.12.....	13
RESISTANCE TO FORCED ENTRY: CSA A440-00, CLAUSE 10.13:.....	13
DEADLOAD DEFLECTION: CSA A440-00, CLAUSE 10.14	13
ENERGY RATING: CSA A440-00, CLAUSE 10.15	13
Window Ratings – Tables of Minimum Requirements from CSA-A440-00 Windows	14
Comments/Conclusion:	15
APPENDIX A.....	16

List of Tables

Table 1: Test Equipment	3
Table 2: Test Sequence and Alterations	4
Table 3: Test Results (Window Ratings).....	5

Sampling Plan/Procedures:

One unused, glazed 300 Series Horizontal Sliding Window complete with all hardware, was provided by the client and examined at the QAI laboratory, then tested between July 26, 2006 August 1, 2006 as being a typical regular production sample of the model covered in this report.

Test Equipment:

Table 1: Test Equipment

Equipment Used:	QAI Laboratory Code:	Calibration Due:
Omega FL910G (0-2.7 cfm) Air Flow Meter	FLOW3	October 2006
Omega FL911G (0-10.2 cfm) Air Flow Meter	FLOW4	October 2006
Dwyer Manometer (0-250 kPa)	MANOMETER1	Adjusted to zero before test
Dwyer Manometer (0-1500 kPa)	MANOMETER2	Adjusted to zero before test
Dwyer Manometer (0-6000 kPa)	MANOMETER3	Adjusted to zero before test
Tuf-E-Nuf Measuring Tape	LENGTH1	October 2008
Spray Rack	SPRAYRACK1	Verified using test procedure described in ASTM Standard E547.
Mititoyo Calipers	CALIPER1	Verified with gauge block before use
Gauge block (0.125", 0.25", 0.5")	GAUGEBLOCK1 GAUGEBLOCK2 GAUGEBLOCK3	May 2007
Pressure Regulator, Pressure Gauge and pneumatic cylinders calibrated together as complete system.	CYLINDER1,2,3, REGULATOR1,2,3 GAUGE1,2,3	System verified with LOADCELL5
Load Cell	LOADCELL5	Verified with weights. Weights verified with SCALE3.
Excell Scale FA 132 (0-30kg)	SCALE3	September 2006
Spring Balance	PULL1	Verified with weights. Weights verified with SCALE3 before use.
Dial Gauge	DIAL1	Verified with gauge block before use
Dial Barometer	BAROMETER1	August 2007
Thermocouple	TC-1	June 2007
Sash Pull Off Clamp (CSA A440-00, Figure 8)	SASHPULL1	Adjusted and weighed using SCALE3 before each test

Test Conditions:

Quality Auditing Institute Ltd. (QAI) was retained by Oasis Windows Ltd. to perform testing in accordance with the test requirements of CSA A440-00 "Windows" on a representative sample of 300 Series Horizontal Sliding Window.

This report includes the tests performed on a specimen of specific dimensions. Actual product performance may be affected by variations in the windows dimensions, assembly details and installation method. The drawings supplied by Oasis Windows were verified by QAI for the window unit tested and are shown in Appendix A.

As directed by the manufacturer, the window specimen was installed in a test buck using #8 x 1 1/2" screws 8" spacing along the jambs and sill. A bead of Window and Door silicone sealant was applied to the side of the window flange mating with the surface of the wooden test buck. One full tube (750ml) of silicone was used for each installation.

The wooden test buck consisted of a 84" x 84" square, 3/4" plywood surface reinforced with nominal 2" x 6" stud backing. The center of the buck was built with a rough opening measuring 3/4" larger than the test specimen in length and width, framed in by nominal 2" x 6" members to facilitate mounting of the test specimen. For each test conducted, the test specimen was leveled and set plumb in the wooden test buck.

Table 2: Test Sequence and Alterations

Test Number	Test Clause	Test	Alterations
1	10.9	Ease of Operation	None
2	10.2	Air Leakage	None
3	10.3	Water Penetration	None
4	10.4	Wind Load Resistance	None
5	10.4	Wind Load Resistance	A 3/8" thick wood shim was placed between the midpoint of the window frame head and the 2x6 wooden test buck frame. Sheet metal brackets were placed at 4" spacing over top of the vinyl flange along the frame head. Brackets acted to hold the vinyl flange against the wooden test buck but allowed for vertical movement of the frame. Result: C4 rating increased to C5 rating.
6	10.6	Blocked Operation	None
7	10.11	Sash Pull off	None
8	10.13	Forced Entry	None

Summary of Results:

Table 3: Test Results (Window Ratings)

Clause	Test Name	Rating
10.2	Air Tightness	A3
10.3	Water Tightness	B5
10.4	Wind Load Resistance	C5
10.5	Safety Drop	-
10.6	Blocked Operation	PASS
10.7	Sash Strength and Stiffness, Casement	-
10.8	Sash Strength and Stiffness, Projecting	-
10.9	Ease of Operation	PASS
10.10	Screen Strength	-
10.11	Sash Pull-Off	PASS
10.12	Condensation Resistance	-
10.13	Resistance to Forced Entry	F1

Note: "-" indicates test was not performed

Window Components:

300 Series Horizontal Sliding Window		
Frame:	Size:	Width: 1600mm, Height: 1000mm Vinyl. Part number BX311. See appendix A for drawing.
	Joints:	Mitered. Thermally welded. Corners cleaned.
Sash:	Size:	Width: 31 ½", Height: 37 ½" Vinyl. Part number BX303. See appendix A for drawing.
	Joints:	Mitered. Thermally welded. Corners cleaned.
Interlock:	Mullion:	Vinyl. Part number BX305. See appendix A for drawing. Fastened with 2 - #8 x 3" screws per end, caulked in place.
	Sash Interlock:	Vinyl. Part number BX323. Part number BX324 is equivalent except pull handle is located in a different location. See appendix A for both drawings.
	Reinforcement:	Steel U-Channel (0.060" thick x 0.75" wide x 0.70" high) located in both mullion and sash interlock. Fastened to vinyl member with 10 - ¾" self taping screws. Screws caulked in place.
Glazing Method:	Glazing Tape	Venture #VG116W-L819 (1/16" x 3/8") double sided foam glazing tape applied in one continuous piece and butted together at the end with a bead of silicone caulking.
	Glazing Bead	Vinyl. Snap on. Part number BX309.
	Setting Blocks	Dimensions: 24mm x 24mm x 3mm Poly Chlor – 85 durometer flexible PVC 2 setting blocks beneath each insulated glass unit, each located approximately 50mm from corner of glazing.
Glazing:	Overall Thickness	¾" thick (19mm) 2 glass lites – each 3mm clear annealed
	Spacer:	12.7mm (1/2") Bayform thermally broken, desiccant filled aluminum bar with polysulfide seal.
Weather-stripping	Sash:	Primary Seal (face of sash): Amesbury Group #22018745WHGF continuous around face of sash.
Drainage:	Frame / Sash:	See drawing in appendix A.
Hardware:	Lock:	1 – "Full Max" cam lock #V1L10WH with keeper Fastened using 4 - #6 x 3/4" zinc screws
	Night Lock:	1 – "Full Max" night lock #V1L22WH fastened to left side of sash meeting rail using 2 – 5/32" aluminum tri-fold rivets
	Sill Track	Vinyl. Part number BX357. See drawing in appendix A.
	Anti-lift Block	Vinyl. Part number BX316. See drawing in appendix A.

See appendix A for cross section, assembly, and dimensional specifications.

Test Specifications:

Air Tightness Test: CSA A440-00, Clause 10.2, Test Method: ASTM E283

	Laboratory Conditions	Standard Conditions
Temperature	25.3 C	20.8 C
Pressure	101.7 kPa	101.3 kPa
Air Density	1.188 kg/m ³	1.202 kg/m ³
Air Density Ratio = 0.994		

CL_{op} = Crack length of operable portion = 3.321m

CL_f = Crack length of fixed portion = 3.159m

CL_t = CL_{op} + CL_f = 6.480m

Q_{op/A3} = Maximum air leakage of operable portion for A3 rating = 0.55 (m³/h)/m

Q_f = Maximum air leakage of fixed portion for fixed rating = 0.25 (m³/h)/m

Q_c = Maximum air leakage rate for the slider to obtain A3 Rating

$$= \frac{Q_{op} \times CL_{op} + Q_f \times CL_f}{CL_t} = 0.404 \text{ (m}^3\text{/h)/m}$$

Infiltration Results (positive pressure) @ 75 Pa

Adjusted Metered Air Flow @ 75 Pa ¹	1.943 m ³ /h
Crack Length	6.480 m
Air Infiltration @ 75 Pa¹ (1.57 psf)	0.300 (m³/h)/m

Exfiltration Results (negative pressure) @ -75 Pa

Adjusted Metered Air Flow @ 75 Pa ¹	2.145 m ³ /h
Crack Length	6.480 m
Air Exfiltration @ 75 Pa¹ (1.57 psf)	0.331 (m³/h)/m

Window Air Rating Average

Air Infiltration Rate	0.300 (m ³ /h)/m
Air Exfiltration Rate	0.331 (m ³ /h)/m
Average Rate	0.315 (m³/h)/m
Rating	A3

Notes: ¹ +/- 2.5 Pa Instrument Precision

Alterations during Testing:

None

Water Tightness Test: CSA A440-00, Clause 10.3, Test Method: ASTM E547

Testing performed in accordance with ASTM E547 – 00. Window installed according to the manufacturers instructions for field installation in the test chamber with all operable lites in the closed and latched position. Insect screens were not supplied with the sample.

Test Results:

Pressure Differential	Time	Comments	Rating
300 Pa	5 minutes with pressure 1 minute no pressure	No water leakage	
300 Pa	5 minutes with pressure 1 minute no pressure	No water leakage	
300 Pa	5 minutes with pressure 1 minute no pressure	No water leakage	
300 Pa	5 minutes with pressure 1 minute no pressure	No water leakage	PASS B3
400 Pa	5 minutes with pressure 1 minute no pressure	No water leakage	
400 Pa	5 minutes with pressure 1 minute no pressure	No water leakage	
400 Pa	5 minutes with pressure 1 minute no pressure	No water leakage	
400 Pa	5 minutes with pressure 1 minute no pressure	No water leakage	PASS B4
500 Pa	5 minutes with pressure 1 minute no pressure	No water leakage	
500 Pa	5 minutes with pressure 1 minute no pressure	No water leakage	
500 Pa	5 minutes with pressure 1 minute no pressure	No water leakage	
500 Pa	5 minutes with pressure 1 minute no pressure	No water leakage	PASS B5
600 Pa	5 minutes with pressure 1 minute no pressure	No water leakage	
600 Pa	5 minutes with pressure 1 minute no pressure	No water leakage	
600 Pa	2 minutes, 30 seconds with pressure	Water spilled over sill	FAIL B6

Alterations during Test:

None

The test specimen obtained a B5 Rating

Wind Load Resistance Test: CSA A440-00, Clause 10.4, Test Method: ASTM E330

Testing was performed in accordance with the procedure outlined in ASTM E330 – 02. No conclusions of any kind regarding the adequacy or inadequacy of the glass in the test specimen are to be drawn from this test. Ambient conditions in the lab were 23 degrees Celsius, 102 kPa. Deflection measurements were taken at the center position of the sash interlock as well as 16 ¾" to the top and bottom of the center position. All measurements are in inches.

Try for C3 Rating:

Deflection Test: 1200 Pa (inward direction)

Dial Position	Initial Reading	Pressurized Deflection	Final Reading	Deflection
Top	0.253	0.518	0.256	0.265
Middle	0.442	0.778	0.446	0.336
Bottom	0.267	0.433	0.270	0.166

Deflection = 0.121"

Deflection Test: -1200 Pa (outward direction)

Dial Position	Initial Reading	Pressurized Deflection	Final Reading	Deflection
Top	0.237	0.022	-	0.215
Middle	0.415	0.130	-	0.285
Bottom	0.236	0.069	-	0.167

Deflection = 0.094"

Maximum allowable deflection = $L/125 = 0.268$ "

Blow-Out Test:

Pressure (Pa)	Time (s)
1500	60
0	60
3000	10
0	60
-1500	60
0	60
-3000	10

After pressure was released, window showed no signs of breakage, permanent deformation or operational malfunction.

Alterations during Test:

None

The test specimen obtained a C3 Rating

Try for C4 Rating:

Deflection Test: 1600 Pa (inward direction)

Dial Position	Initial Reading	Pressurized Deflection	Final Reading	Deflection
Top	0.252	0.550	-	0.298
Middle	0.441	0.898	0.447	0.457
Bottom	0.266	0.477	-	0.206

Deflection = 0.205"

Deflection Test: -1600 Pa (outward direction)

Dial Position	Initial Reading	Pressurized Deflection	Final Reading	Deflection
Left	0.256	0.021	-	0.235
Middle	0.479	0.029	-	0.450
Right	0.281	0.067	-	0.214

Deflection = 0.226"

Maximum allowable deflection = $L/125 = 0.268$ "

Blow-Out Test:

Pressure (Pa)	Time (s)
2000	60
0	60
4000	10
0	60
-2000	60
0	60
-4000	10

After pressure was released, window showed no signs of breakage, permanent deformation or operational malfunction.

Alterations during Test:

None

The test specimen obtained a C4 Rating

Try for C5 Rating:

Deflection Test: 2000 Pa (inward direction)

Dial Position	Initial Reading	Pressurized Deflection	Final Reading	Deflection
Top	0.283	0.551	0.285	0.268
Middle	0.315	0.875	0.317	0.560
Bottom	0.328	0.585	0.330	0.257

Deflection = 0.298"

Maximum allowable deflection = $L/125 = 0.268$ "

The test specimen did not obtain a C5 Rating.

Try for C5 Rating:

Deflection Test: 2000 Pa (inward direction)

Dial Position	Initial Reading	Pressurized Deflection	Final Reading	Deflection
Top	0.254	0.538	0.257	0.284
Middle	0.291	0.816	0.293	0.525
Bottom	0.228	0.470	0.232	0.242

Deflection = 0.262"

Deflection Test: -2000 Pa (outward direction)

Dial Position	Initial Reading	Pressurized Deflection	Final Reading	Deflection
Top	0.218	-0.080	0.212	0.298
Middle	0.830	0.290	0.816	0.540
Bottom	0.182	-0.070	0.170	0.252

Deflection = 0.265"

Maximum allowable deflection = $L/125 = 0.280$ "

Blow-Out Test:

Pressure (Pa)	Time (s)
2500	60
0	60
5000	10
0	60
-2500	60
0	60
-5000	10

After pressure was released, window showed no signs of breakage, permanent deformation or operational malfunction.

Alterations during Test:

A 3/8" thick wood shim was placed between the midpoint of the window frame head and the 2x6 wooden test buck frame. Sheet metal brackets were placed at 4" spacing over top of the vinyl flange along the frame head. Brackets acted to hold the vinyl flange against the wooden test buck but allowed for vertical movement of the frame.

The test specimen obtained a C5 Rating

Safety Drop – Vertical Sliding Windows: CSA A440-00, Clause 10.5:

Not Applicable

Blocked Operation Test: CSA A440-00, Clause 10.6:

With the window mounted in the test frame and the operable lite blocked with a 2" strip of 5/8" plywood in the closed position at one end of the meeting rail, the force specified in Table 11 of CSA A440-00 (180 N) was applied to the handle in the opening direction for 60 seconds. The test was repeated with the operable lite blocked in the open position and the force applied in a closing direction.

Deflection of sash with force applied in the opening direction = 0.2mm

Deflection of sash with force applied in the closing direction = 0.2mm

The test specimen showed no signs of failure or permanent deformation.

The test specimen PASSED the Blocked Operation Test

Sash Strength and Stiffness: CSA A440-00, Clause 10.7:

Not Applicable

Sash Strength and Stiffness: CSA A440-00, Clause 10.8:

Not Applicable

Ease of Operation Test: CSA A440-00, Clause 10.9:

The window was mounted in a test frame and the operable lite was moved from the fully closed to the fully open position and back three times to ensure that the lite was operating freely. See Table 9 of CSA A440-00 for test requirements.

Opening Direction:

Force to Initiate Motion = 10.5 lb

Force to Maintain Motion = 7.5 lb

Closing Direction:

Force to Initiate Motion = 4.5 lb

Force to Maintain Motion = 7.8 lb

Force to operate handles = 4.1 lb

Alterations during Testing:

None

The test specimen PASSED the Ease of Operation Test

Insect Screen Strength CSA A440-00, Clause 10.10:

Insect screens were not supplied with the test specimen.

Sash Pull-Off CSA A440-00, Clause 10.11:

Testing was performed in accordance with Clause 11.11 of CSA A440-00.

A weight of 265 N (59.6 lb) was applied to the midpoint of the meeting stile for 60 seconds. The maximum allowable mid-span sash deflection is 7.1 mm (75% of net glazing engagement).

Location	Load	Deflection
Meeting Rail	265 N	3.6 mm

The test specimen **PASSED** the Sash Pull-Off Test

Condensation Resistance: CSA A440-00, Clause 10.12

This test was not performed at the request of the manufacturer.

Resistance to Forced Entry: CSA A440-00, Clause 10.13:

Testing was performed in accordance with Clause 11.13 of CSA A440-00. No entry was gained during the specified time of hand and tool manipulation performed prior to and following the application of the following loads on the hardware:

Time (T1) = 5 minutes
 Time (T2) = 5 minutes
 Load (L1) = 666 N (150 lb)
 Load (L2) = 333 N (75 lb)
 Load (L3) = 111 N (25 lb)

Test A1 = Pass
 Test A2 = Pass
 Test A3 = Pass
 Test A4 = Pass
 Test A5 = Pass
 Test A6 = N/A
 Test A7 = Pass

The test specimen obtained a F1 Rating

Deadload Deflection: CSA A440-00, Clause 10.14

Not applicable.

Energy Rating: CSA A440-00, Clause 10.15

This test was not performed at the request of the manufacturer.

Window Ratings – Tables of Minimum Requirements from CSA-A440-00 Windows

Table 1: Air Tightness

Window Rating	Maximum Air Leakage Rate (m ³ /h)/m
Storm	8.35 (max)
	5.00 (min)
A1	2.79
A2	1.65
A3	0.55
Fixed	0.25

Table 2: Water Tightness

Window Rating		
For use in small buildings	For use in other buildings	Pressure Differential (Pa)
Storm	--	0
B1	B1	150
B2	B2	200
B3	B3	300
	B4	400
	B5	500
	B6	600
	B7	700

Table 3: Wind Load Resistance

Window Rating		Pressure Differential, Pa	
For use in small buildings	For use in other buildings	Deflection	Blowout
		Sash (L/125)	
Storm	--	--	750
C1	C1	500	1500
C2	C2	750	2000
C3	C3	1200	3000
	C4	1600	4000
	C5	2000	5000

Comments/Conclusion: (Include tests subcontracted, variances from test methods, statement of compliance, statement of estimated uncertainty, opinions and interpretations used and their basis. Attach extra pages as necessary: No of pages attached _____)

Quality Auditing Institute Ltd., with lab facilities located in Port Moody, British Columbia, performed testing in accordance with CSA A440-00 on a representative sample of Oasis Windows 300 Series Horizontal Sliding Window.

Test results in this report may not be reproducible in the field. Test results relate only to those products tested.

See Table 3 for a summary of the test results and window ratings.

Person(s) Authorizing Report:

	<u>KENT ADAMSON</u>	<u>MANAGER</u>	<u>12/09/06</u>
Name (Signature)	Name (Printed)	Title	(dd/mm/yy)

Reviewed by:

	<u>BEN BARKER</u>	<u>MANAGER</u>	<u>12/09/06</u>
Name (Signature)	Name (Printed)	Title	(dd/mm/yy)

APPENDIX A

Window Drawings 300 Series Single Slider

Page	Title
A1	300 Series Single Slider Window
A2	BX311 Mainframe
A3	BX305 Tilt Mullion
A4	BX303 Sash
A5	BX324 Sash w/ Interlock and Handle
A6	BX323 Sash w/ Interlock
A7	BX309 ¾" Glazing Bead
A8	BX357 Sill Track
A9	BX316 Anti-Lift Block
A10	Drainage

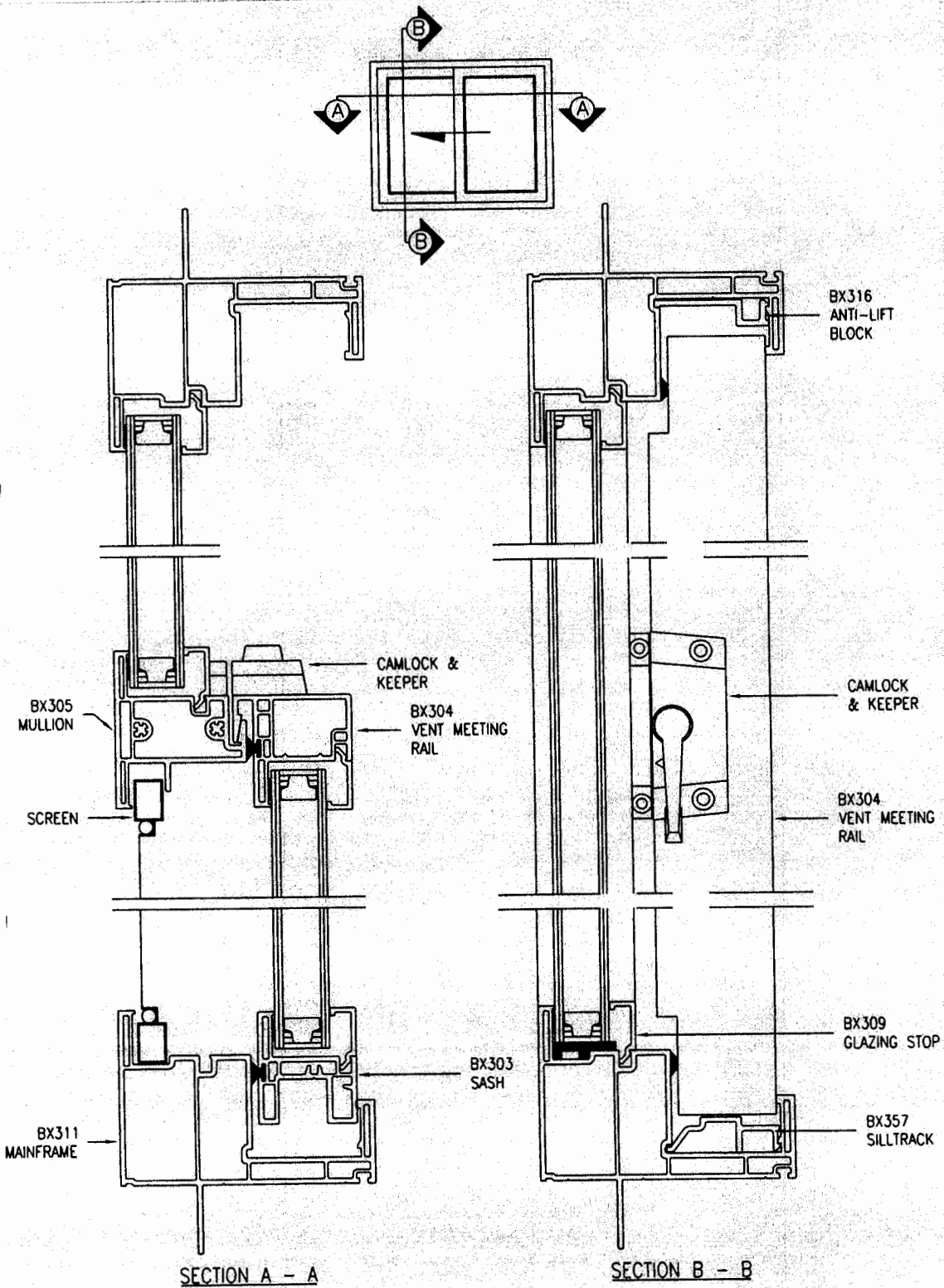

BERLINEX
 4350 - 68 AVENUE
 EDMONTON, ALBERTA T6B 2P3
 CANADA

NOTE: The copyright in this drawing is the property of BerlineX and neither the drawing nor any part of it, nor any information contained therein, shall be reproduced or disclosed to any third party other than for the purpose of the use of the company product.

Part Number:	-
Description:	300 Series Single Slider Window
Dwg No./Dwn By:	300 Series Single Slider / D.Feil
Date / Revision:	May 18/2006/01
Drawing Size:	Scale: NTS

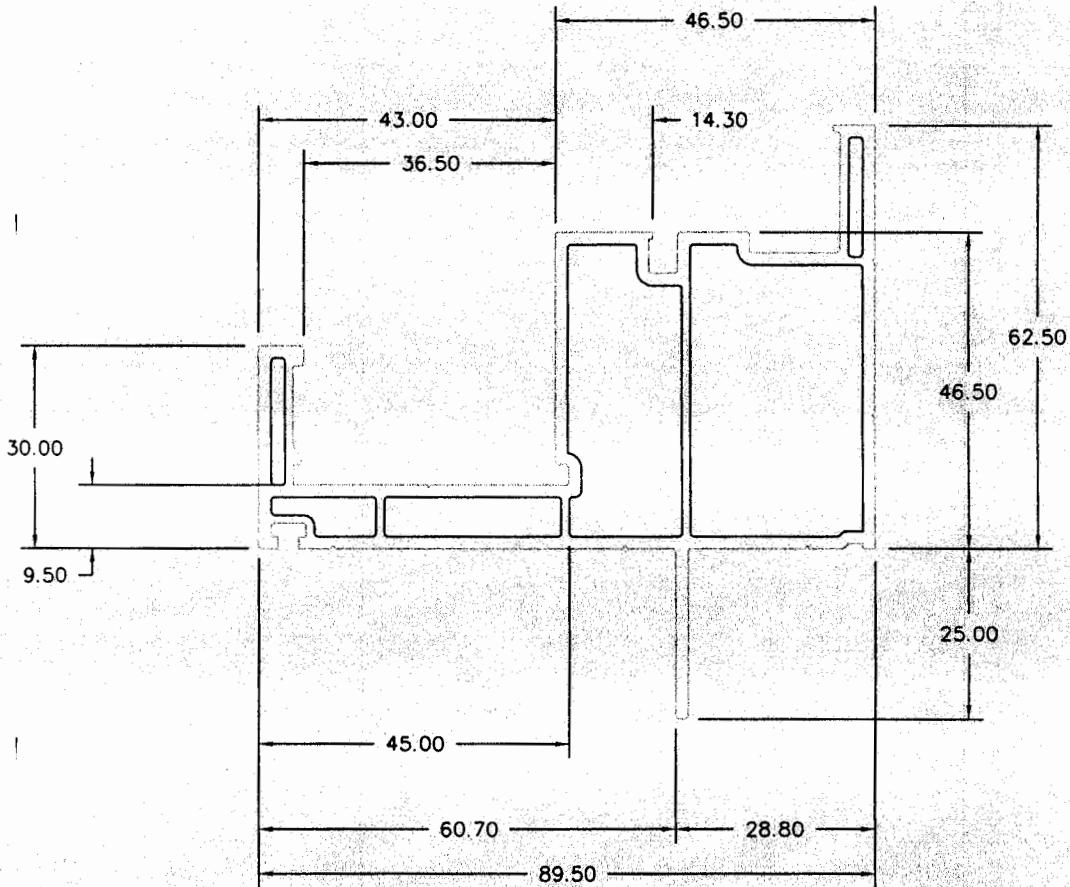

Berlinex Inc. 4350 - 68 Avenue Edmonton, Alberta T6B 2P3 Canada	Approved for:	Part Number:	BX311
	Function:	Description:	MAINFRAME
Dimension:	Viability:	Dwg No./Dwn By:	BX311rev4 / D.Feil
		Date / Revision:	October 12/2004/04
Note: The copyright in this drawing is the property of the above company, and neither the drawing nor any part of it, nor any information contained therein, shall be reproduced or disclosed to any third party other than for the purpose of the use of the company product.	Date:	Drawing Size:	SCALE 1:1
		Ext. Wall Thks.:	1.8 mm
		Int. Wall Thks.:	1.2 mm
		Not Spec. Radii:	0.5 mm
		Area:	
		Weight:	

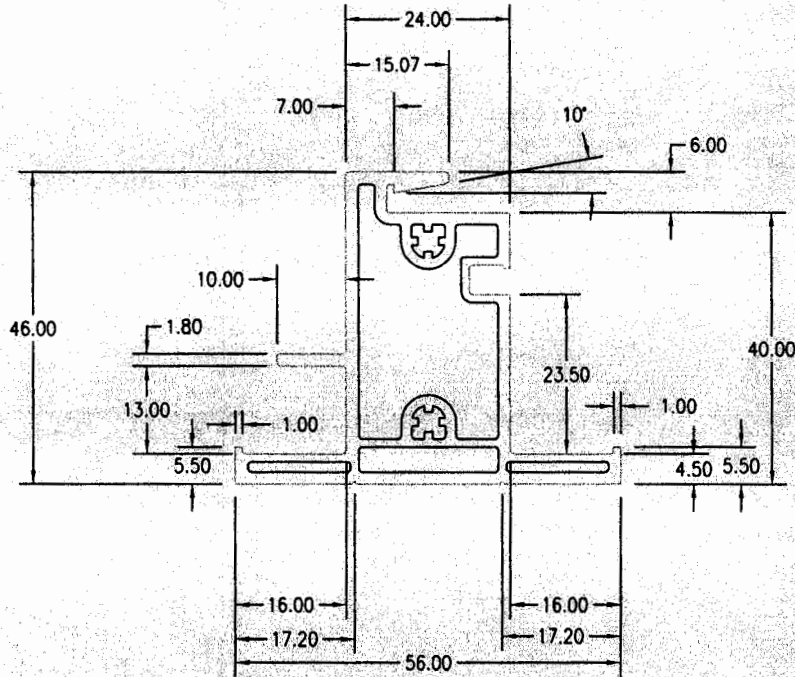

Ext. Wall Thks.:	1.8 mm		
Int. Wall Thks.:	1.5 mm		
Not Spec. Radii:	0.5 mm		
Overall Area:			
Overall Weight:			
Rigid Weight:	-		
Flex Weight:	-		
		REVISIONS	DATE
BERLINEX 4350 - 68 AVENUE EDMONTON, ALBERTA T6B 2P3 CANADA	NOTE: The copyright in this drawing is the property of Berlinex and neither the drawing nor any part of it, nor any information contained therein, shall be reproduced or disclosed to any third party other than for the purpose of the use of the company product.	Part Number: BX305 Description: TILT MULLION Dwg No./Dwn By: BX305rev8 Date / Revision: May 25/2004/08 Drawing Size: SCALE 1:1	

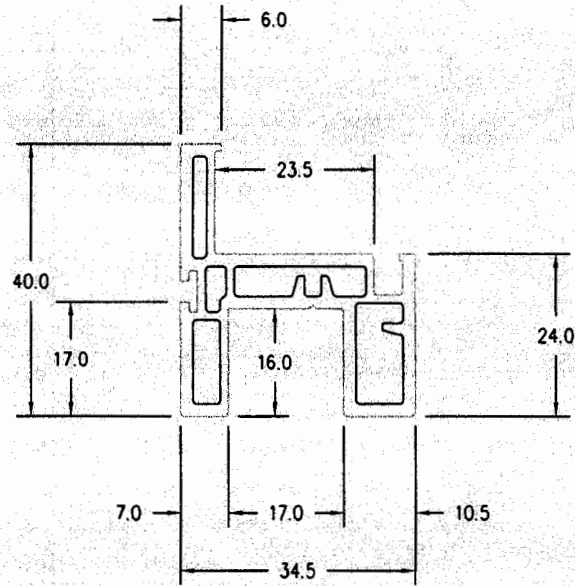

Berlinex Inc.
 4350 - 68 Avenue
 Edmonton, Alberta T6B 2P3
 Canada

Note: The copyright in this drawing is the property of the above company, and neither the drawing nor any part of it, nor any information contained therein, shall be reproduced or disclosed to any third party other than for the purpose of the use of the company product.

Approved for:	Part Number:	BX303
Function:	Description:	SASH
Dimension:	Dwg No./Dwn By:	BX303rev6 / D.Feit
Viability:	Date / Revision:	October 12/2004/06
Date:	Drawing Size:	SCALE 1:1
	Ext. Wall Thks.:	1.8 mm
	Int. Wall Thks.:	1.2 mm
	Not Spec. Radii:	0.5 mm
	Area:	
	Weight:	

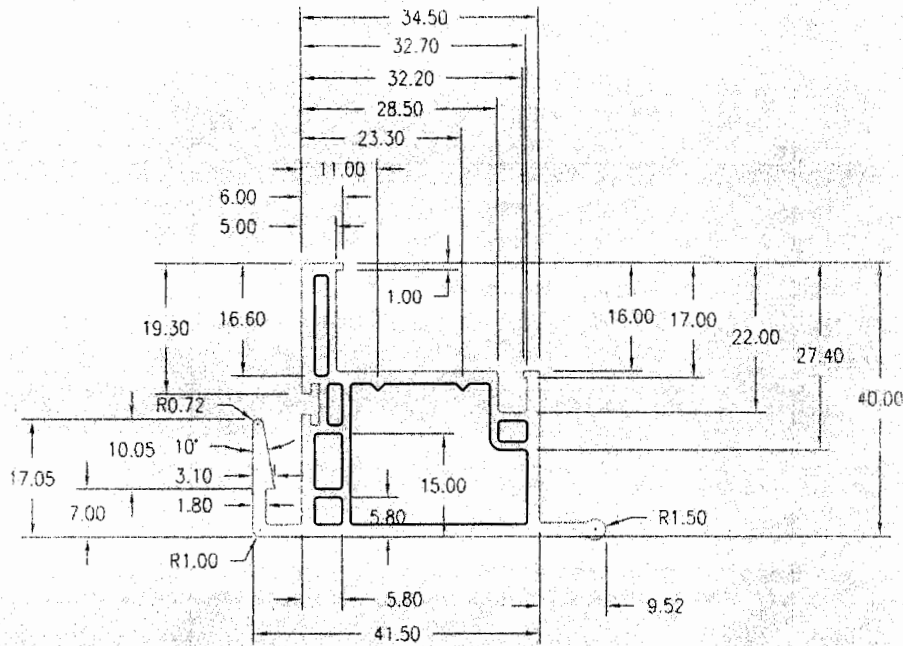

Ext. Wall Thks.:	1.8 mm		
Int. Wall Thks.:	1.2 mm		
Not Spec. Radii:	0.5 mm		
Overall Area:			
Overall Weight:			
Rigid Weight:	-		
Flex Weight:	-		
		REVISIONS	DATE

VEKA CANADA
 4350 - 68 AVENUE
 EDMONTON, ALBERTA T6B 2P3
 CANADA

NOTE: The copyright in this drawing is the property of VEKA CANADA and neither the drawing nor any part of it, nor any information contained therein, shall be reproduced or disclosed to any third party other than for the purpose of the use of the company product.

Part Number:	BX324
Description:	SASH w/ INTERLOCK & HANDLE
Dwg No./Dwn By:	BX324
Date / Revision:	March 14/2006
Drawing Size:	SCALE 1:1

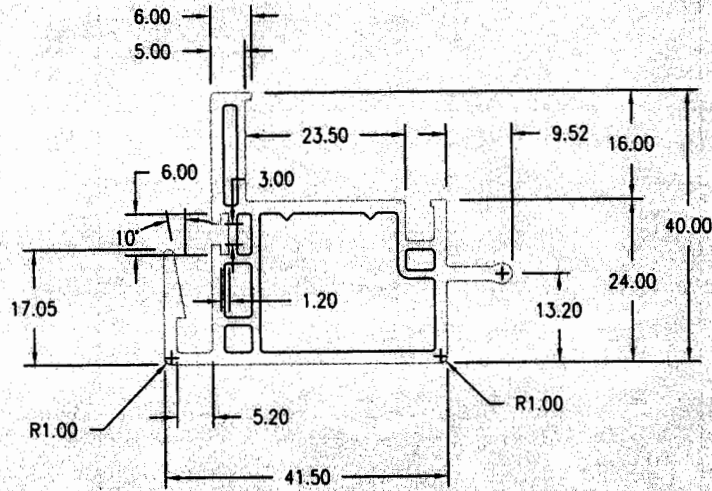

Ext. Wall Thks.:	1.8 mm			
Int. Wall Thks.:	1.2 mm			
Not Spec. Radii:	0.5 mm			
Overall Area:				
Overall Weight:				
Rigid Weight:	-			
Flex Weight:	-			
BERLINEX		REVISIONS		DATE
4350 - 68 AVENUE		Part Number:	BX323	
EDMONTON, ALBERTA T6B 2P3		Description:	SASH w/ INTERLOCK (CO-EX PULL HANDLE)	
CANADA		Dwg No./Dwn By:	BX323	
NOTE: The copyright in this drawing is the property of Berlinex and neither the drawing nor any part of it, nor any information contained therein, shall be reproduced or disclosed to any third party other than for the purpose of the use of the company product.		Date / Revision:	November 08/2004/02	
		Drawing Size:	SCALE 1:1	

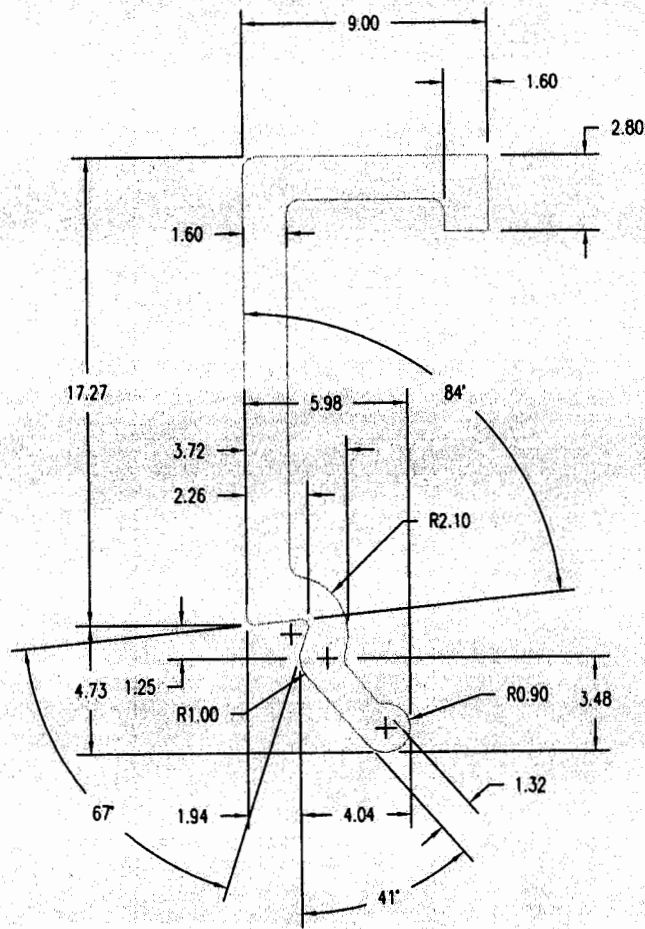

Scale 1:1

Berlinex Inc.
 4350 - 68 Avenue
 Edmonton, Alberta T6B 2P3
 Canada

Note: The copyright in this drawing is the property of the above company, and neither the drawing nor any part of it, nor any information contained therein, shall be reproduced or disclosed to any third party other than for the purpose of the use of the company product.

Approved for:	Part Number:	BX309
Function:	Description:	3/4" Glazing Bead
Dimension:	Dwg. No./Dwn By:	BX309 / D.Feil
Viability:	Date / Revision:	October 09/2001/02
Date:	Drawing Size:	SCALE 4:1 unless otherwise specified
	Ext. Wall Thks.:	
	Int. Wall Thks.:	
	Not Spec. Radii:	
	Area:	
	Weight:	

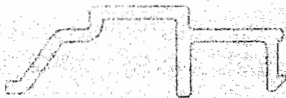
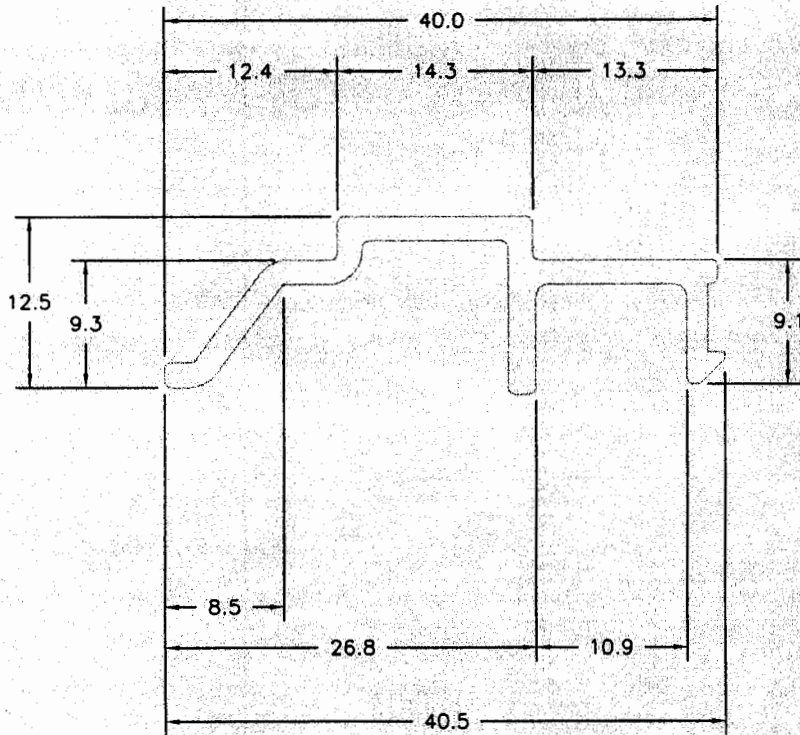

SCALE 1:1

Berlinex Inc.
 4350 - 68 Avenue
 Edmonton, Alberta T6B 2P3
 Canada

Note: The copyright in this drawing is the property of the above company, and neither the drawing nor any part of it, nor any information contained therein, shall be reproduced or disclosed to any third party other than for the purpose of the use of the company product.

Approved for:	Part Number:	BX357
Function:	Description:	SILLTRACK
Dimension:	Dwg No./Dwn By:	BX357 / D.Feil
Viability:	Date / Revision:	October 17/2001/02
Date:	Drawing Size:	SCALE 2:1 unless specified otherwise
	Ext. Wall Thks.:	1.8 mm
	Int. Wall Thks.:	-
	Not Spec. Radii:	0.5 mm
	Area:	
	Weight:	

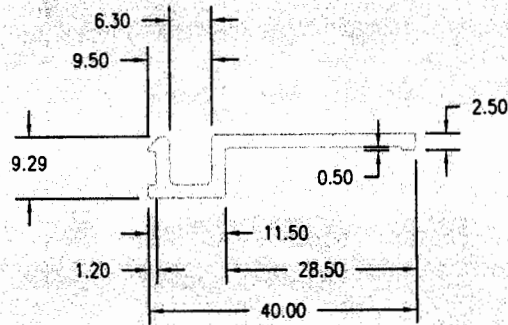

Berlinex Inc.
 4350 - 68 Avenue
 Edmonton, Alberta T6B 2P3
 Cahada

Note: The copyright in this drawing is the property of the above company, and neither the drawing nor any part of it, nor any information contained therein, shall be reproduced or disclosed to any third party other than for the purpose of the use of the company product.

Approved for:	Part Number:	BX316
Function:	Description:	ANTI-LIFT BLOCK
Dimension:	Dwg No./Dwn By:	BX316 / D.Feil
Viability:	Date / Revision:	October 09/2001/03
Date:	Drawing Size:	SCALE 1:1
	Ext. Wall Thks.:	2.0 mm
	Int. Wall Thks.:	-
	Not Spec. Radii:	0.5 mm
	Area:	
	Weight:	

SINGLE SLIDER WINDOW

Test Report

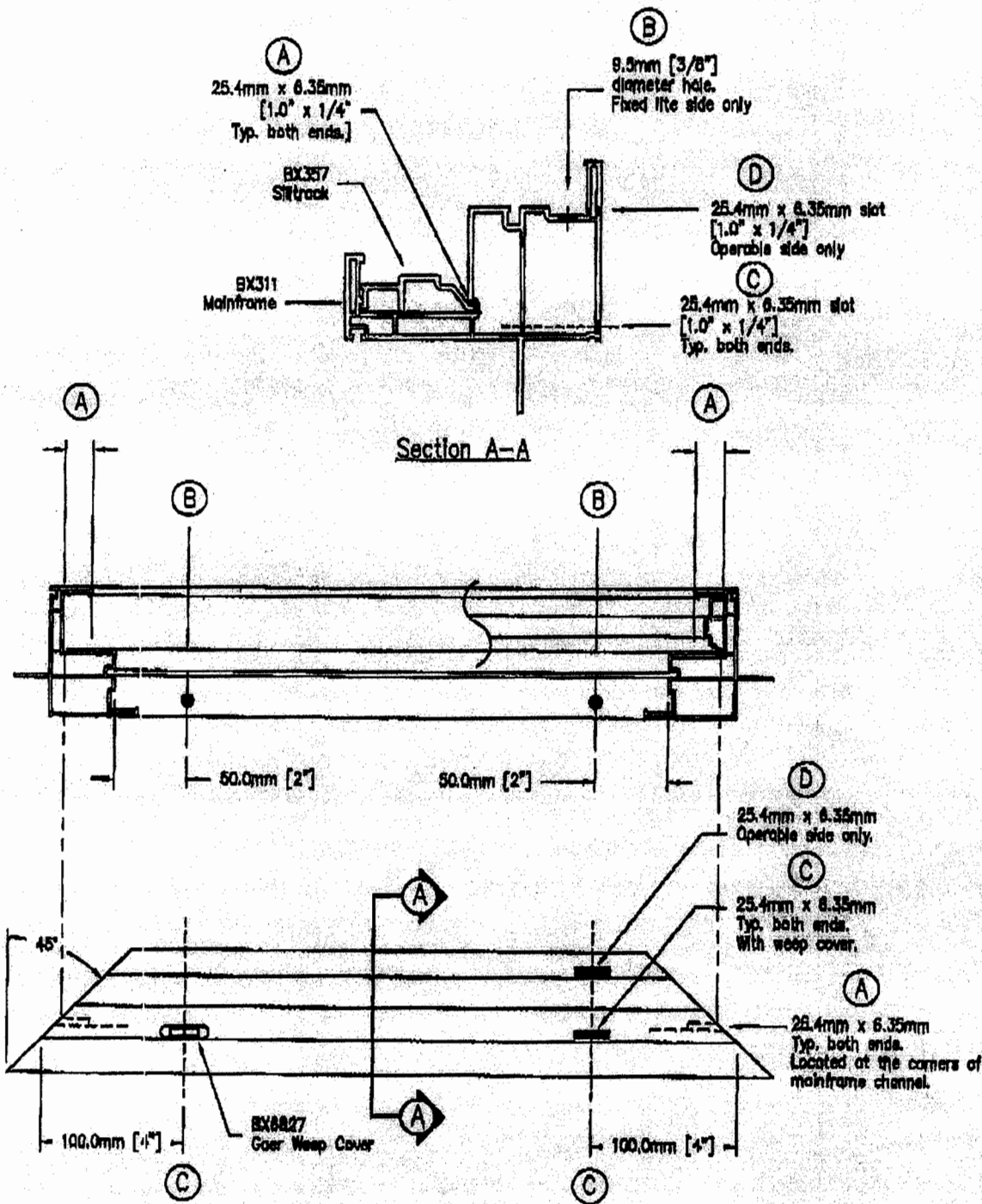

VEKA CANADA
 4350 - 88 AVENUE
 EDMONTON, ALBERTA T6B 2P3
 CANADA

NOTE: The copyright in this drawing is the property of VEGA Canada and neither the drawing nor any part of it, nor any information contained therein, shall be reproduced or disclosed to any third party without the prior written consent of VEGA Canada for the purposes of the use of the respective product.

Part Number:	---
Description:	300 Series Drainage - Slider (OASIS)
Desig. No./Drawn By:	300drainage / D.Fel
Date / Revision:	August 28/2006
Drawing Size:	Scale: NTS